

## General Description

The OSU78L05 is fixed-voltage monolithic integrated-circuit voltage regulators designed for a wide range of applications. These applications include on-card regulation for elimination of noise and distribution problems associated with single-point regulation. In addition, they can be used with power-pass elements to make high current voltage regulators.

The internal limiting and thermal shutdown features of regulators make them essentially immune to overload. Current limiting is included to limit the peak output current (250mA ~ 300mA) to a safe value. When used as a replacement for a zener diode-resistor combination, an effective improvement in output impedance can be obtained together with lower-bias current.

## Features

- Operating Voltage Range: 7.0~35V
- Maximum Output Current: 150mA
- Output Voltage: 5.0V
- Low Dropout Voltage: 1700mV@100mA
- Output Voltage Accuracy of  $\pm 5\%$  over the Full Temperature Range
- Good Transient Response
- Integrated Short-Circuit Protection
- Over-Temperature Protection
- Over Voltage Protection
- Output Current Limit
- Low Temperature Coefficient
- Stable with Ceramic Capacitor
- RoHS Compliant and Lead (Pb) Free
- -40°C to +85°C Operating Temperature Range
- Available in Green SOT23 , SOT89-3 Packages

## Applications

- Consumer Electronics
- Microprocessor Power Supply
- Mother Board

**Application Circuits**

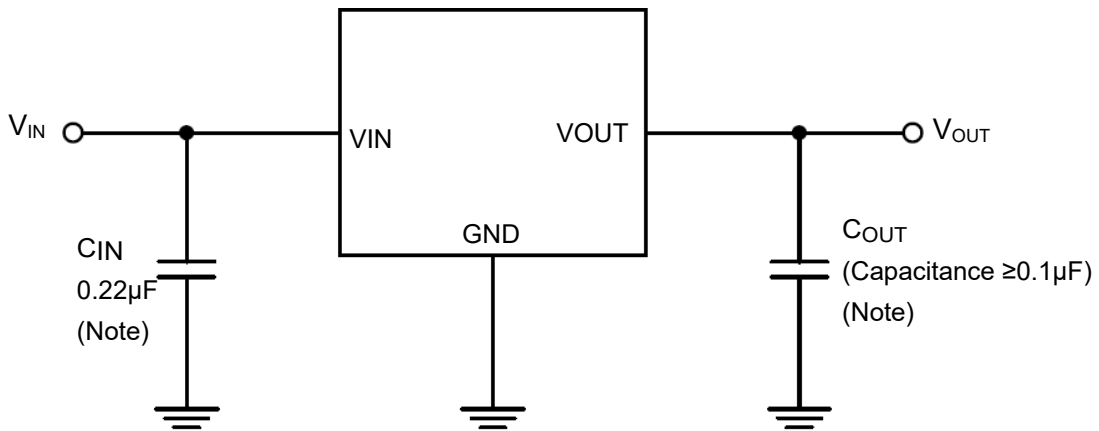
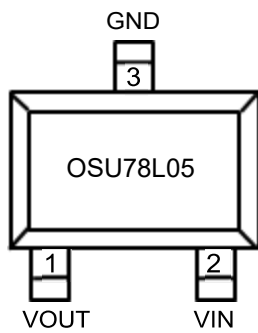

Figure 1. OSU78L05 Typical Application Circuit

Note: Bypass capacitors are recommended for optimum stability and transient response and should be located as close as possible to the regulators.

**Pin Configuration (TOP VIEW)**

SOT23:



SOT89-3:

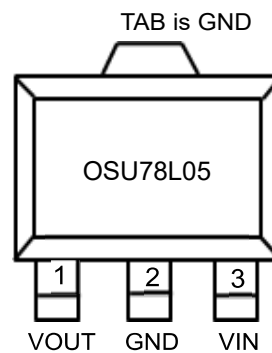

**Pin Description**

Pin No.		Pin Name	Pin Function
SOT23	SOT89-3		
1	1	VOUT	Output Voltage
2	3	VIN	Power Input
3	2	GND	Ground

**Order Information**

OSU78L①②③

Designator	Symbol	Description
①②	Integer e.g 5.0V=05	Output Voltage 5.0V
③	TE / TS	Package: SOT23 / SOT89-3

Part NO.	Marking	Description	Package	T/R Qty
OSU78L05TE	-----	OSU78L05 3-TERMINAL 0.15A POSITIVE VOLTAGE REGULATOR	SOT23	3,000 PCS
OSU78L05TS	-----		SOT89-3L	1,000 PCS

**Marking Information**

For marking information, contact our sales representative directly

### Absolute Maximum Ratings

Item		Symbol	Rating	Unit
Supply Input Voltage		$V_{IN}$	-0.3 ~ 50	V
Regulated Output Voltage		$V_{OUT}$	-0.3 ~ 6.0	V
Output Current		$I_{OUT}$	Internally limited	mA
Power Dissipation $P_D @ T_A = +25^\circ C$	SOT23	$P_D$	280	mW
	SOT89-3		750	
Thermal Resistance (Junction to air)	SOT23-3	$\theta_{JA}$	450	$^\circ C / W$
	SOT89-3		165	
Human Body Model (HBM)			$\pm 2000$	V
Charged Device Mode (CDM)			$\pm 1000$	V
Machine Mode (MM)			200	V
Storage Temperature Range		$T_{STG}$	-65 ~ +150	$^\circ C$
Operating Junction Temperature		$T_J$	+150	$^\circ C$
Lead Temperature (Soldering 10s)		$T_{LEAD}$	+260	$^\circ C$

Note:

- 1、Stresses beyond those listed under Absolute Maximum Ratings may cause permanent damage to the device. These are stress ratings only and functional operation of the device at these conditions is not implied. Exposure to absolute-maximum-rated conditions for extended period may affect device reliability.
- 2、Ratings apply to ambient temperature at +25 $^\circ C$
- 3、The package thermal impedance is calculated in accordance to JESD 51-7.

### Recommended Operating Conditions

Item	Min	Max	Unit
Operating Ambient Temperature	-40	+85	$^\circ C$
Input voltage	7.0	30	V

### Electronic Characteristics

Test Conditions:  $V_{IN}=12V$ ,  $C_{IN}=0.22\mu F$ ,  $C_{OUT}=0.1\mu F$ ,  $I_{OUT}=40mA$ ,  $T_A=25^\circ C$ , unless otherwise specified

Symbol	Parameter	Conditions	Min	Typ	Max	Unit
$V_{OUT}$	Output Voltage	$V_{IN}=12V$ , $I_{OUT}=40mA$	4.9	5.0	5.1	V
		$7V \leq V_{IN} \leq 24V$ , $1mA \leq I_{OUT} \leq 100mA$ $P_D \leq 0.75W$	4.75	---	5.25	
$V_{IN}$	Supply Input Voltage		7	---	35	V
$V_{OVP}$	OVP Threshold	$I_{OUT} = 10mA$	---	35	38	V
$V_{RLINE}$	Line Regulation	$7V \leq V_{IN} \leq 24V$ $I_{OUT} = 10mA$	---	15	70	mV
$V_{RLOAD}$	Load Regulation	$V_{IN} = 12V$ $1mA \leq I_{OUT} \leq 100mA$	---	20	60	mV
$I_Q$	Quiescent Current		---	2.5	5	mA
$\Delta I_Q$	Quiescent Current Change	$7V \leq V_{IN} \leq 24V$	---	0.3	1.0	mA
		$1mA \leq I_{OUT} \leq 40mA$	---	---	1.0	
PSRR	Ripple Rejection	$f=100Hz$ , $7V \leq V_{IN} \leq 24V$	47	62	---	dB
$V_{DROP}$	Dropout Voltage	$I_{OUT} = 100mA$	---	1.7	2	V
		$I_{OUT} = 200mA$	---	2	2.2	
$N_o$	Output Noise Voltage	$10Hz \leq f \leq 100kHz$ (Note)	---	40	---	$\mu V$
$\Delta V_{OUT} / \Delta T$	Output Voltage	$I_{OUT} = 10mA$	---	0.5	---	$mV/^\circ C$
$(\Delta V_{OUT} / \Delta V_{OUT}) / \Delta T$	Temperature Coefficient		---	85	---	ppm/ $^\circ C$

Note : 0.1 $\mu F$  minimum load capacitance is recommended to limit high frequency noise.

**Functional Block Diagram**

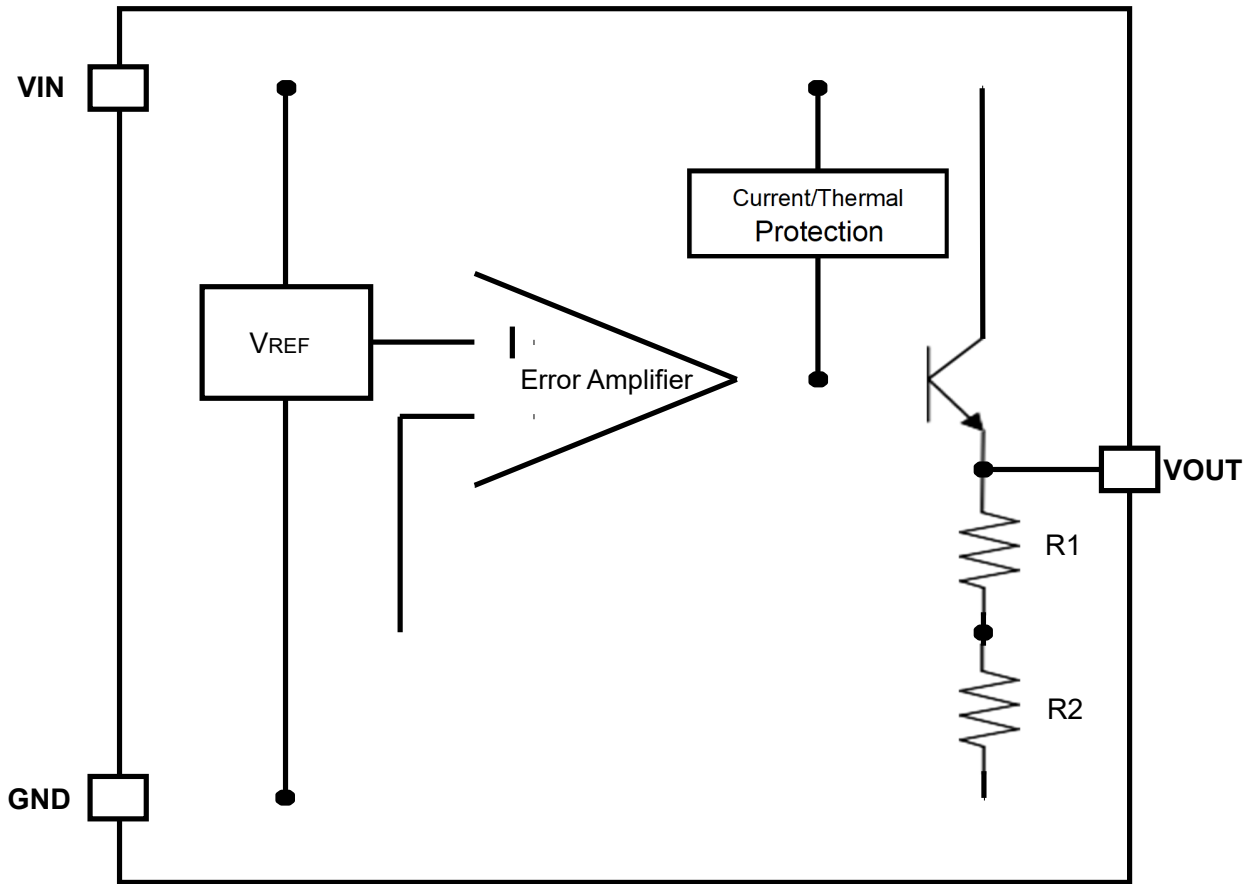
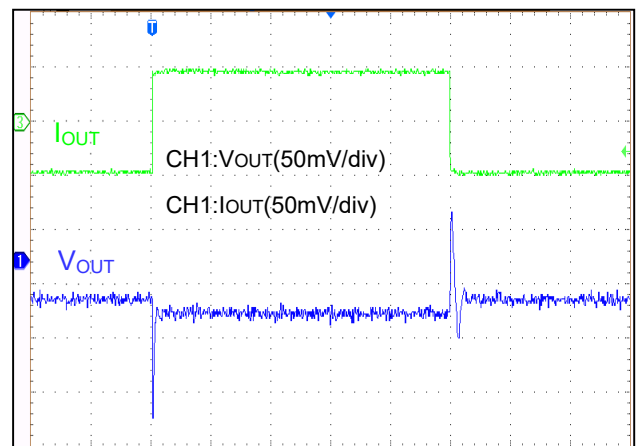
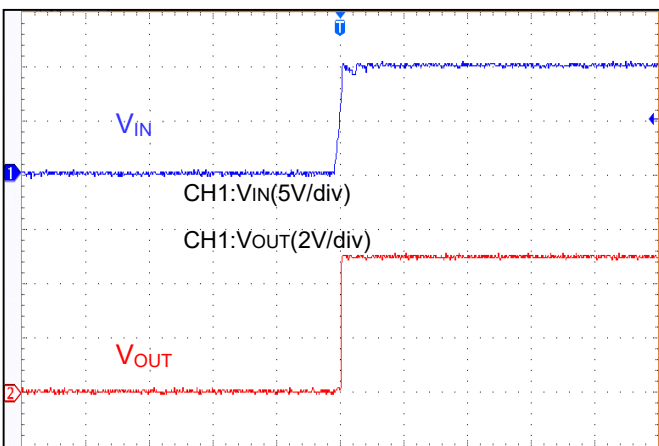
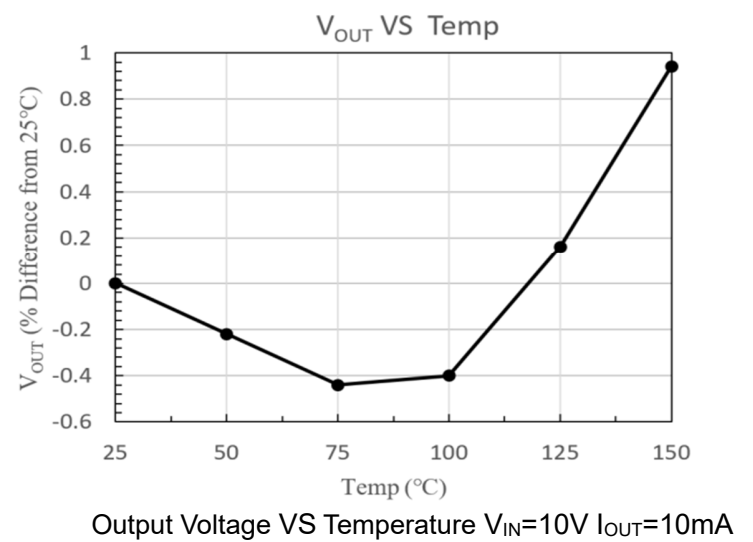
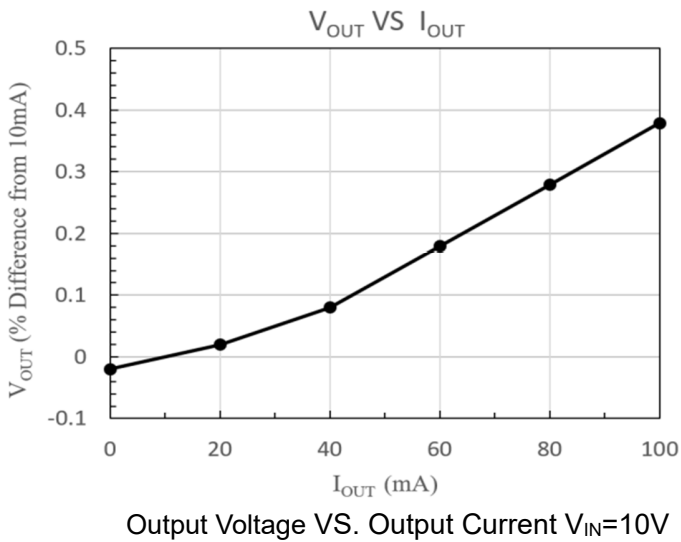
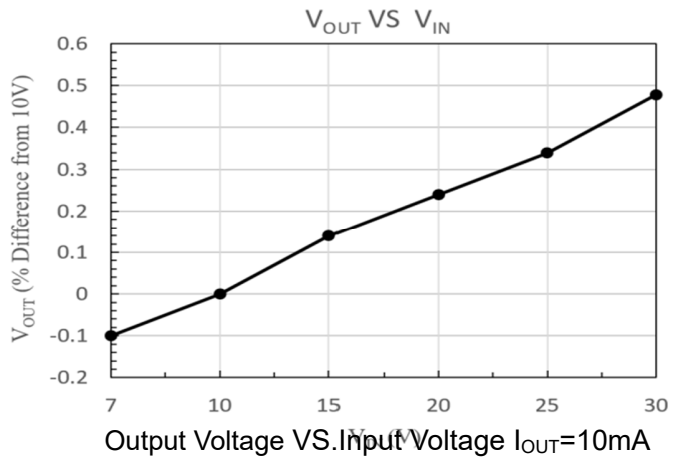
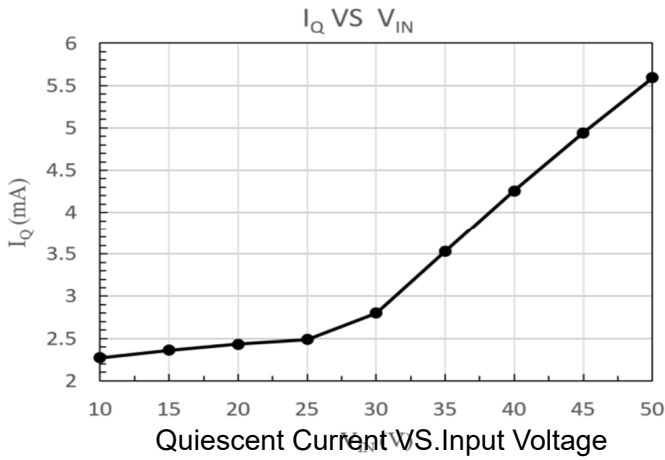

Figure . OSU78L05 Block Diagram

**Typical Performance Characteristics**  $C_{IN}=0.22\mu F, C_{OUT}=0.1\mu F$



## Application Guideline

### ■ Input Capacitor

A 0.22 $\mu$ F ceramic capacitor is recommended to connect between VIN and GND pins to decouple input power supply glitch and noise. The amount of the capacitance may be increased without limit. This input capacitor must be located as close as possible to the device to assure input stability and less noise. For PCB layout, a wide copper trace is required for both VIN and GND.

### ■ Output Capacitor

An output capacitor is required for the stability of the OSU78L05. The recommended output capacitance is 0.1 $\mu$ F, ceramic capacitor is recommended, and temperature characteristics are X7R or X5R. Higher capacitance values help to improve load/line transient response. The output capacitance may be increased to keep low undershoot/overshoot. Place output capacitor as close as possible to VOUT and GND pins.

### ■ Dropout Voltage

The dropout voltage refers to the voltage difference between the VIN and VOUT pins while operating at specific output current. The dropout voltage  $V_{\text{DROP}}$  also can be expressed as the voltage drop on the pass-FET at specific output current ( $I_{\text{RATED}}$ ) while the pass-FET is fully operating at ohmic region and the pass-FET can be characterized as a resistance  $R_{\text{DS(ON)}}$ . Thus the dropout voltage can be defined as ( $V_{\text{DROP}} = V_{\text{IN}} - V_{\text{OUT}} = R_{\text{DS(ON)}} \times I_{\text{RATED}}$ ). For normal operation, the suggested LDO operating range is ( $V_{\text{IN}} > V_{\text{OUT}} + V_{\text{DROP}}$ ) for good transient response and PSRR ability. Vice versa, while operating at the ohmic region will degrade the performance severely.

### ■ Thermal Application

For continuous operation, do not exceed the absolute maximum junction temperature. The maximum power dissipation depends on the thermal resistance of the IC package, PCB layout, rate of surrounding airflow, and difference between junction and ambient temperature. The maximum power dissipation can be calculated as below:

$T_A = 25^\circ\text{C}$ , AISIS DEMO PCB,

The max  $P_D = (T_j - T_A) / \theta_{JA}$ .

Power dissipation ( $P_D$ ) is equal to the product of the output current and the voltage drop across the output pass element, as shown in the equation below:

$$P_D = (V_{IN} - V_{OUT}) \times I_{OUT}$$

### ■ Layout Consideration

By placing input and output capacitors on the same side of the PCB as the OSU78L05, and placing them as close as is practical to the package can achieve the best performance. The ground connections for input and output capacitors must be back to the AM75XXM ground pin using as wide and as short of a copper trace as is practical. Connections using long trace lengths, narrow trace widths, and/or connections through via must be avoided. These add parasitic inductances and resistance that results in worse performance especially during transient conditions.

### Legal Disclaimer

The information given in this document shall in no event be regarded as a guarantee of conditions or characteristics. With respect to any examples or hints given herein, any typical values stated herein and/or any information regarding the application of the device, Oriental Semiconductor hereby disclaims any and all warranties and liabilities of any kind, including without limitation, warranties of non-infringement of intellectual property rights of any third party.

For further information on technology, delivery terms and conditions and prices, please contact the Oriental Semiconductor sales representatives ([www.orientalsemi.com](http://www.orientalsemi.com)).

© Oriental Semiconductor Co.,Ltd. All Rights Reserved 